

Design of Brazed Joints

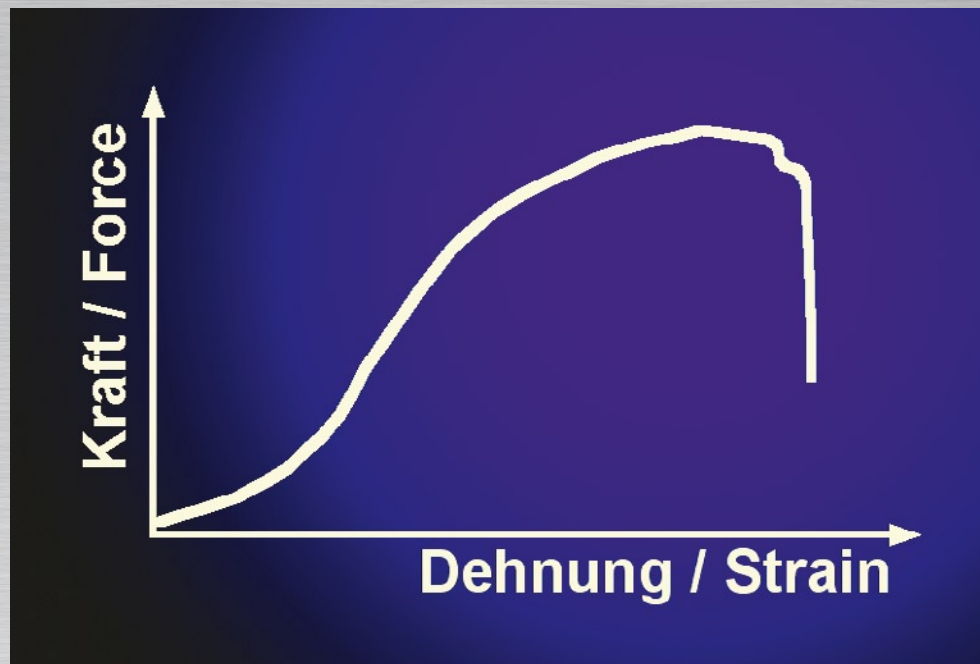

Design of brazed joints

1. Introduction

An optimum brazed joint can only be achieved if there is close co-operation between design and production departments.

A series of constructional considerations must be taken into account before carrying out any brazing work:

First of all the operating conditions (type of load, magnitude of the load and its direction; media, temperatures) must be established. In addition, the base material and any heat treatment it is subjected to must be defined. The brazing alloy and brazing technique are then selected. The fit of the workpieces must be selected depending on the brazing technique.

2. Fits (gap widths)

0 – 0.1 mm	Vacuum-brazing, gap-brazing
0 – 0.2 mm	Inert gas brazing, gap-brazing
0.05 – 0.2 mm	Flux-brazing, gap-brazing by machine
0.05 – 0.5 mm	Flux-brazing, manual gap-brazing
> 0.5	Flux-brazing, manual joint-brazing

3. Sizes of brazed joints

Brazed joints must be of such a size that they can be subjected to as high loads as the base material. The brazed joints are calculated using the laws of the theory of the strength of materials. If one assumes there to be predominantly static loads at room temperature, no major brazing defects and suitable combinations of materials, the following can be used for calculating the brazed joints:

$$\sigma_B \text{ Brazed joint} \approx 200 \text{ MPa (N/mm}^2\text{)}$$

$$\tau_B \text{ Brazed joint} \approx 100 \text{ MPa (N/mm}^2\text{)}$$

As a rule of thumb, an overlap length of between 3 and 6 times the sheet thickness can be used (see Figure 1) or alternatively a value in accordance with the nomogram (see Table 5).

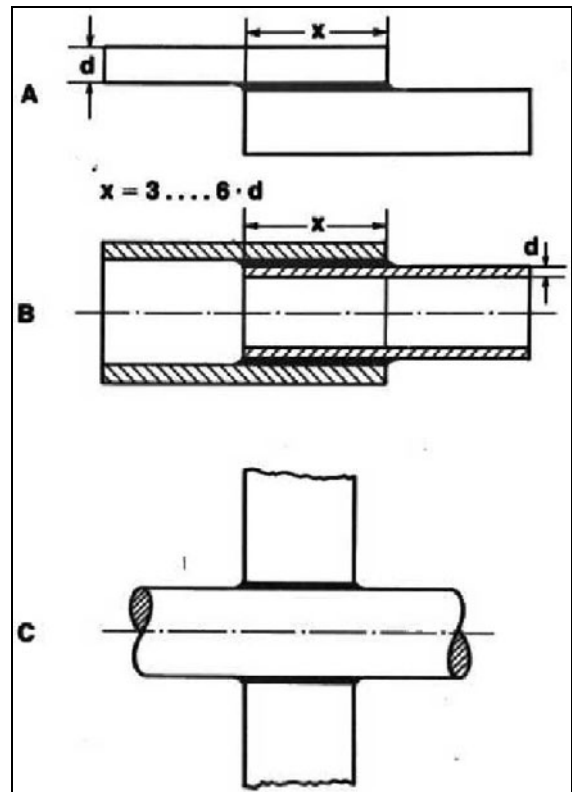

Figure 1: Examples of overlapped gaps

Unnecessarily large overlap lengths lead to more defects and make „through-brazing“ more difficult.

4. Determining the amount of brazing alloy

The required amount of brazing alloy can be calculated from the maximum gap volume, plus ca. 15 % for each fillet to be formed. For cylindrical brazed joints, the wire diameter of the brazing alloy ring can be determined using the nomogram (see Figure 2).

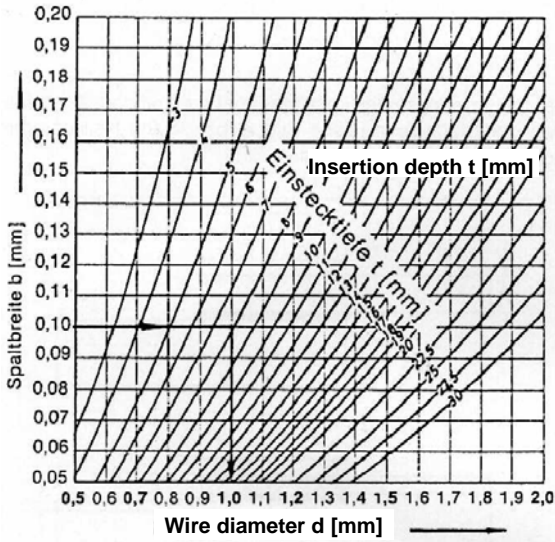

Figure 2: Relationship between the brazed gap width, insertion depth and brazing alloy wire diameter for brazing cylindrical joints

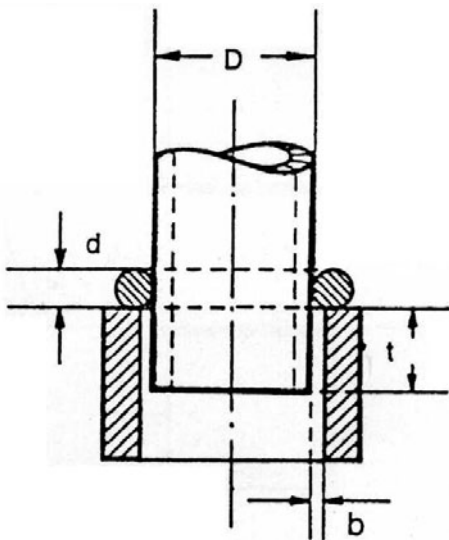

Figure 3: Schematic representation of the arrangement of a brazing alloy wire ring for filling the gap between cylindrical components

b = width of brazed gap
 t = insertion depth
 d = wire diameter

- Read off the gap width from the y-axis (vertical axis)
- Draw a horizontal line from this point to the curve having insertion depth t.
- From the intersection point, draw a vertical line to the x-axis (horizontal axis) and read off the sought after wire diameter d.
- If the answer is an intermediate value, the next larger wire diameter must be chosen.

5. Design regulations

- Make parallel hemmings (see Figure 4)

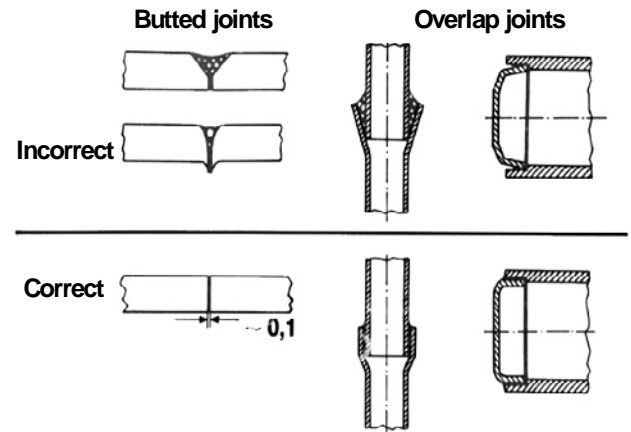

Figure 4: Incorrect and correct gap cross-sections

Design of brazed joints

- On melting, the brazing alloy must maintain contact with the gap. Keep the brazing alloy flow distance as short as possible (see Figure 5).

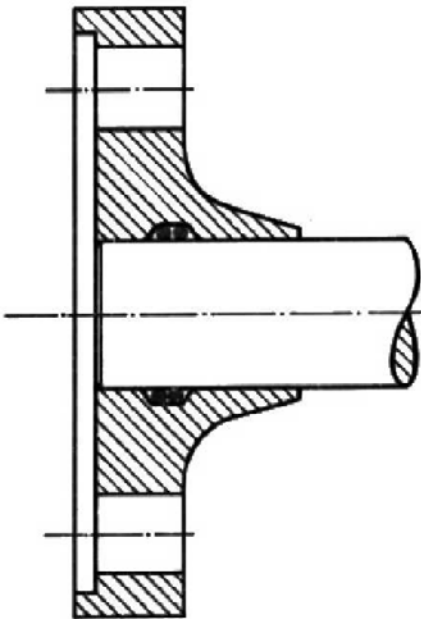

Figure 5: Surface brazing with inserted brazing alloy rings

- If possible, arrange workpieces so that they are self-positioning. When brazing in normal air, a surface press fit may not be used as too little flux is present in the brazing gap to keep the gap walls bare metal. Self-positioning of the components can be achieved using a three-line press fit (see Figure 6) or a knurled press fit (see Figure 7).

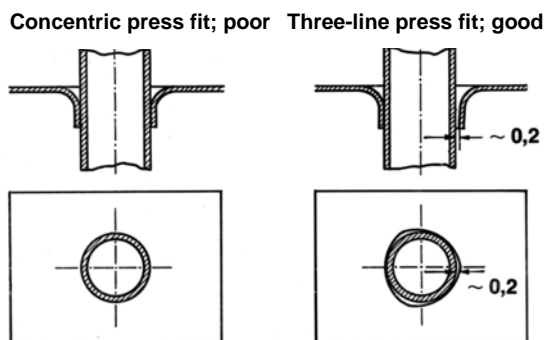

Figure 6: Brazing pressed components
A: Surface press fit; poor
B: Line press fit; good

Surface press fit; poor Knurled press fit; good

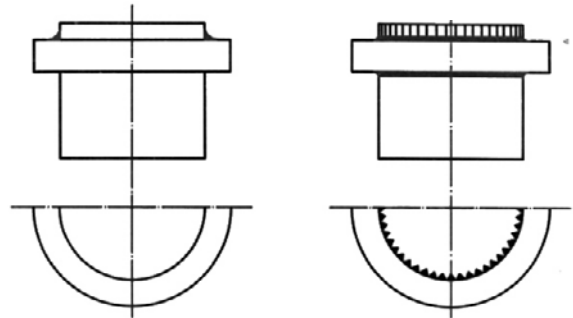

Figure 7: Brazing pressed components
A: Surface press fit; poor
B: Knurled press fit, very good

- Do not sink nipples, bolts, etc. during the brazing procedure on workpieces having diameters > 30 mm due to possible internal stress (see Figure 8).
- Take into account size changes caused by heat expansion when using a combination of different materials so that the required gap width is present at the brazing temperature.
- Make movement of the brazing alloy / flux possible (see Figure 9).

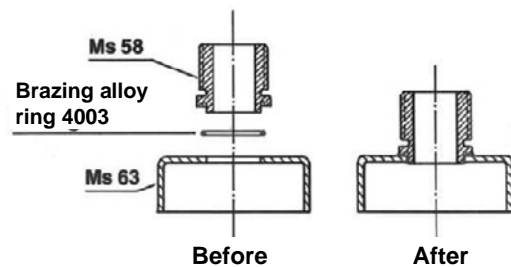

Figure 8: Brazing threaded connection pieces

Design of brazed joints

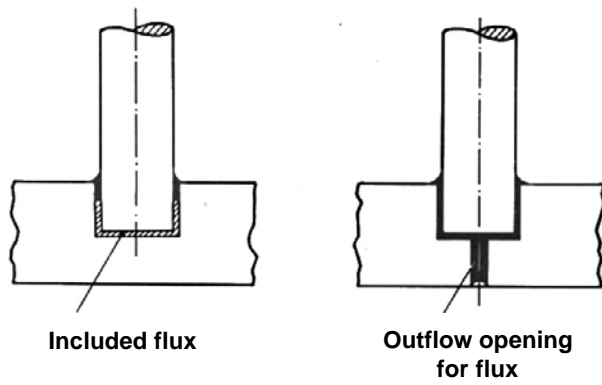

Figure 9: Avoiding flux inclusions

- Avoid erratic changes in cross-section on brazed joints subjected to high loads (see Figure 10).

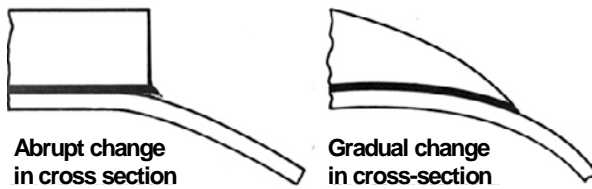

Figure 10: Cross-sectional changes

Keep de-burring-phases small and flat so that they can be filled up with brazing alloy (Figure 11)

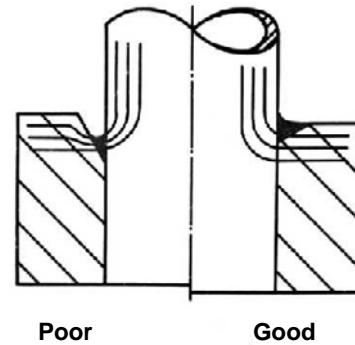

Figure 11: Design of brazed joints

Design of brazed joints

- Containers – connection pieces – brazed joints

Problem: Due to local heating, the connection pieces become larger in diameter but the bore not.

On cooling down the connection piece becomes smaller but the bore not.

Consequence: High stresses in the brazed joint seam with a danger of cracking on cooling down

Solution: Knock out the container walls or weld on brazed connection pieces.

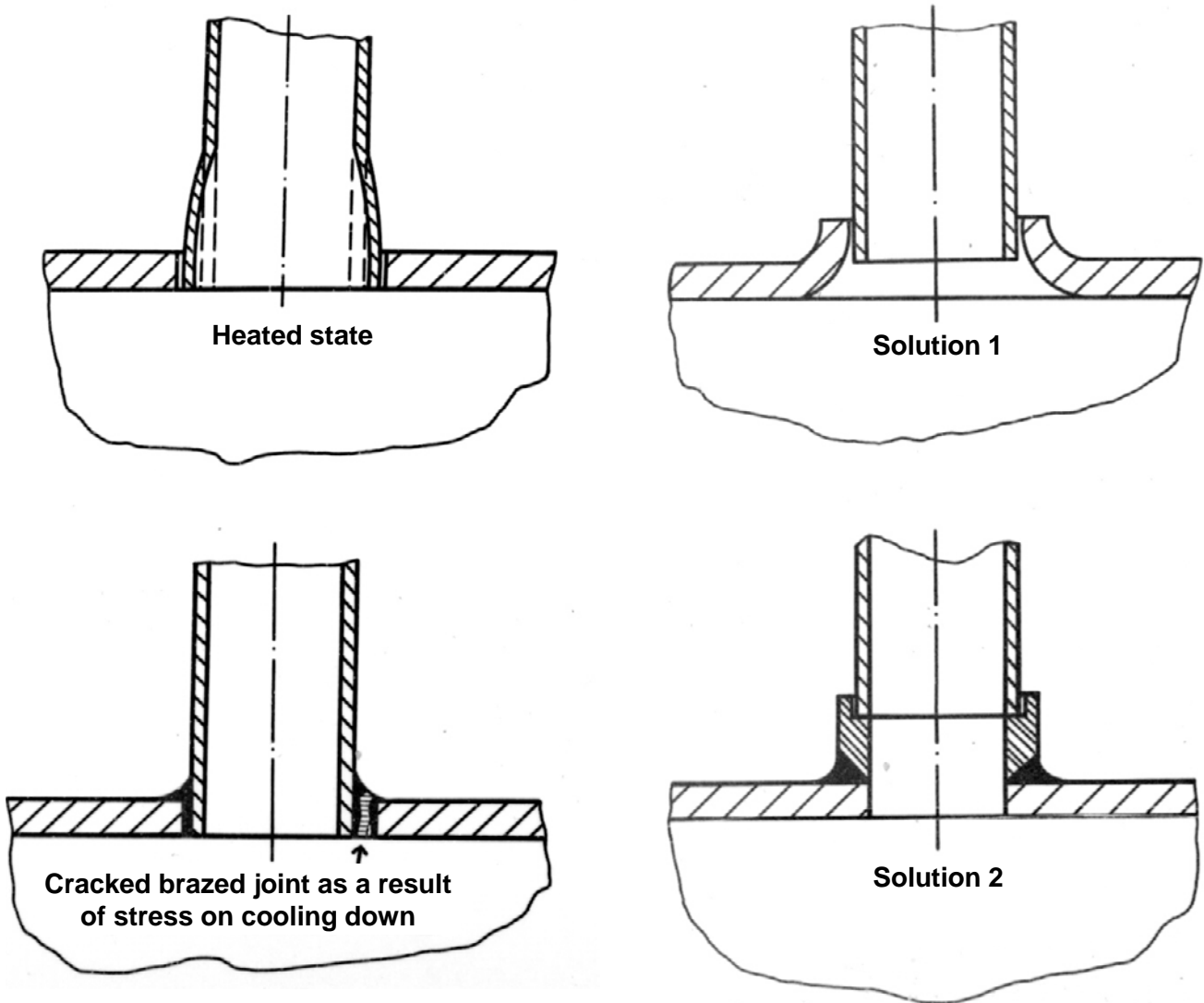

Figure 12 and 13: Brazing pipes into thick-walled containers

6. Examples of constructions (Tables 1 – 4)

BrazeTec brazing alloys in brazed joints

A selection of technically important examples now follows.

(Favourable gap width range: 0.05 ... 0.2 mm; the gap widths are not shown to scale in the tables but are enlarged).

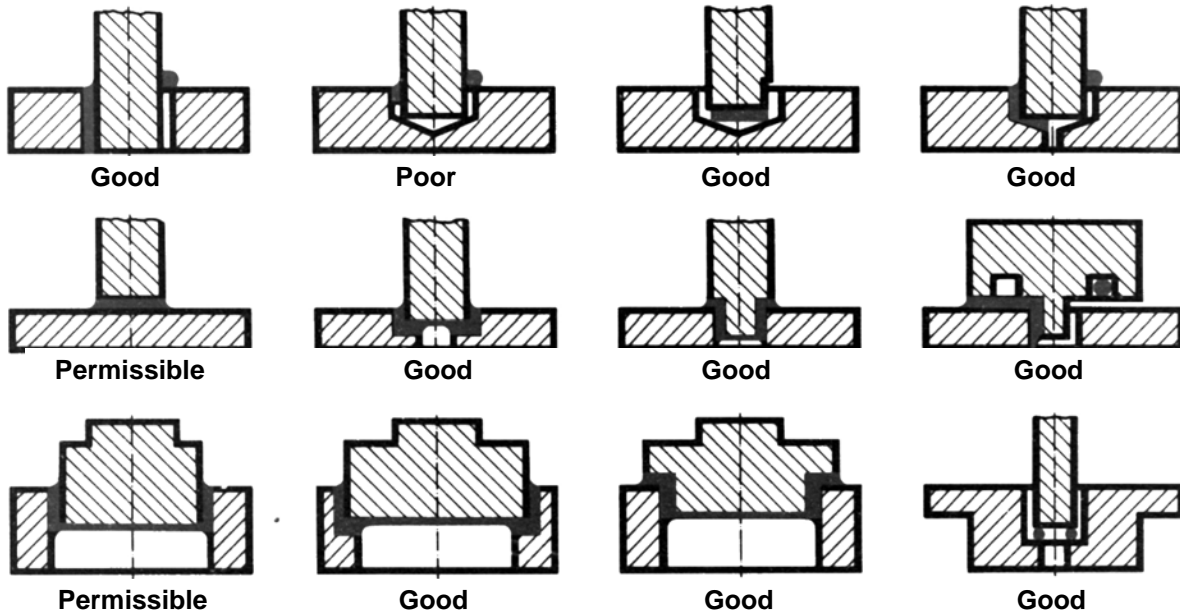

Table 1: Bolts

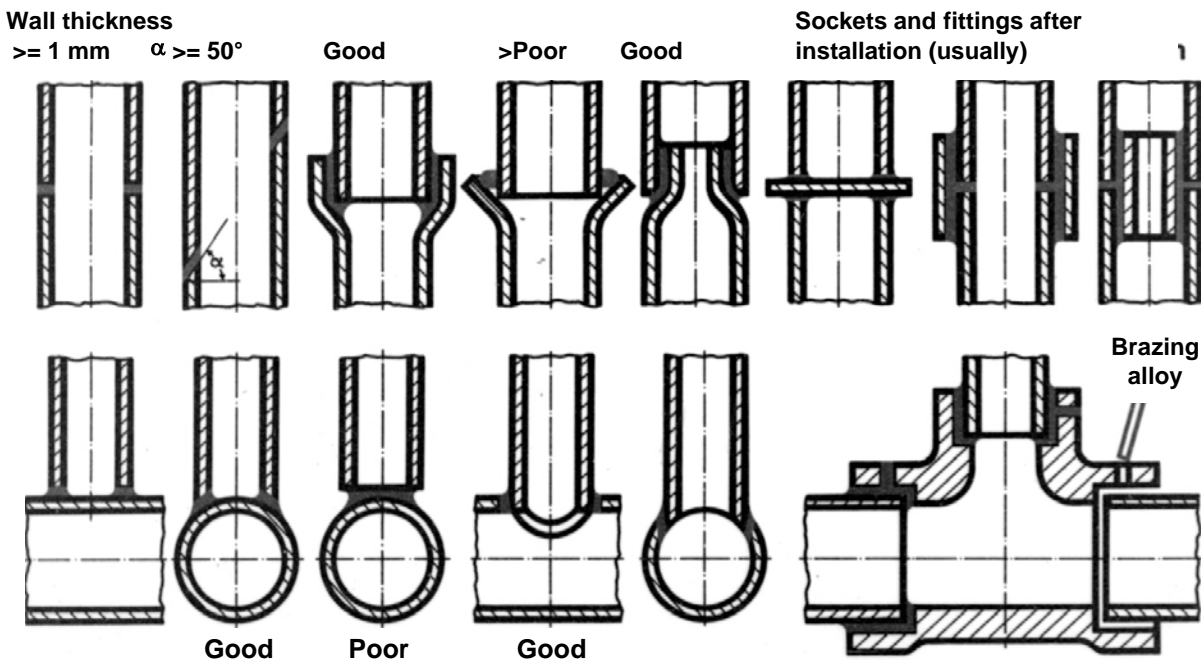

Table 2: Pipes

Design of brazed joints

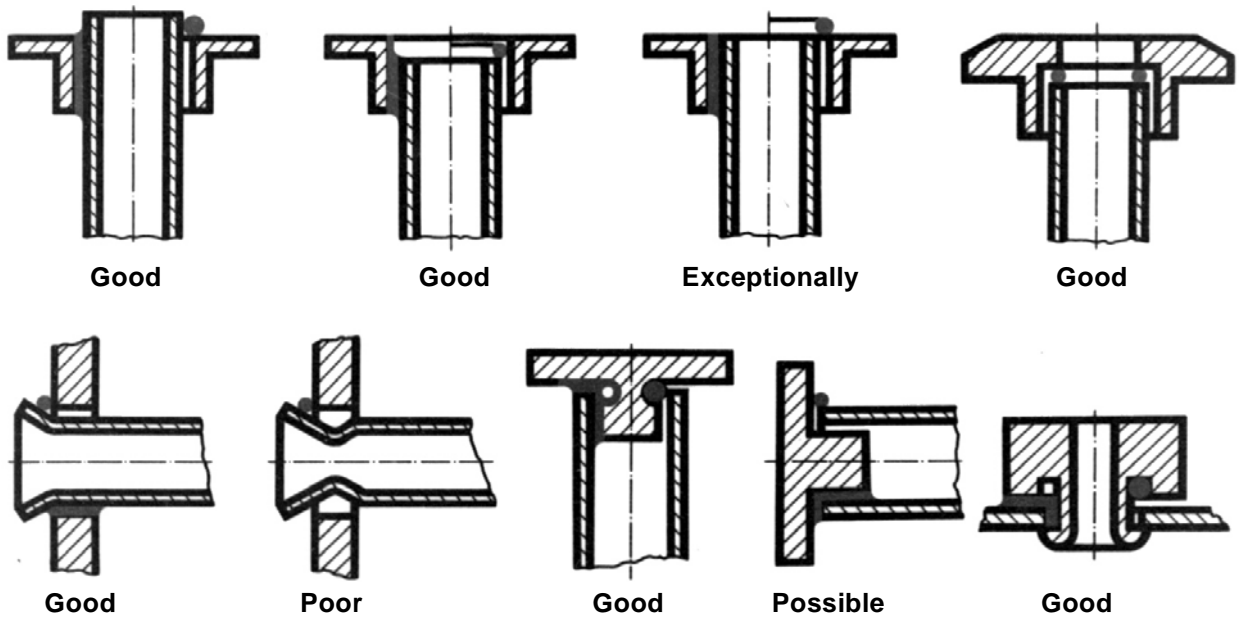

Table 3: Nipples and flanges

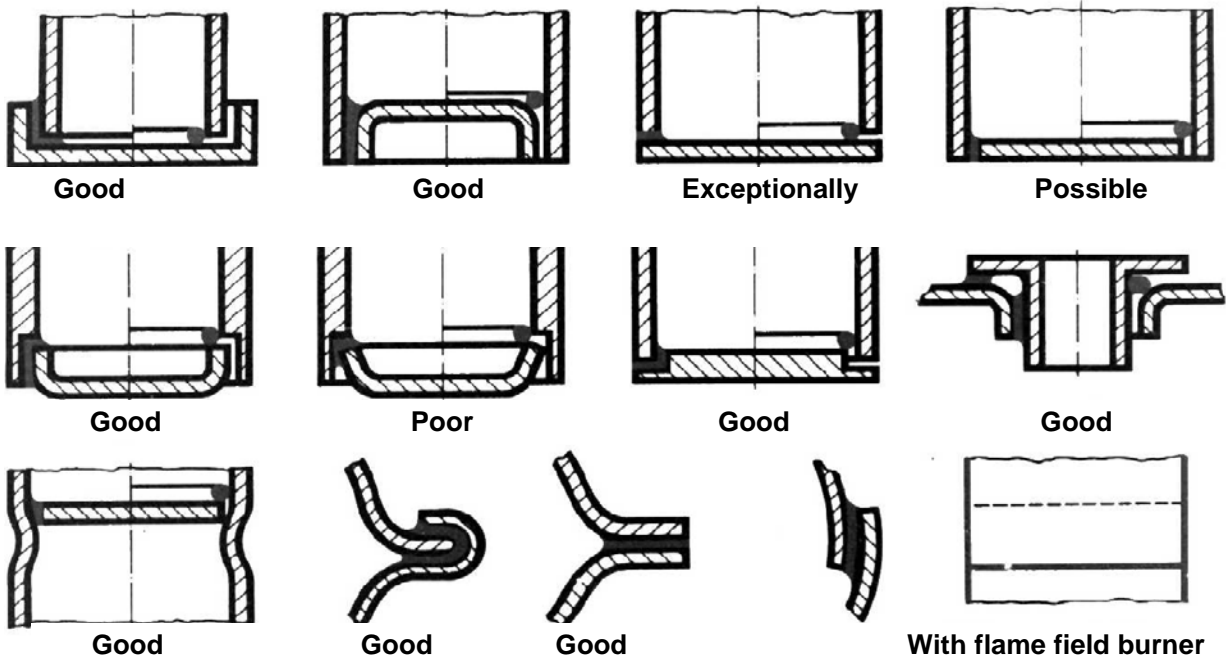

Table 4: Containers made of sheet metal

Design of brazed joints

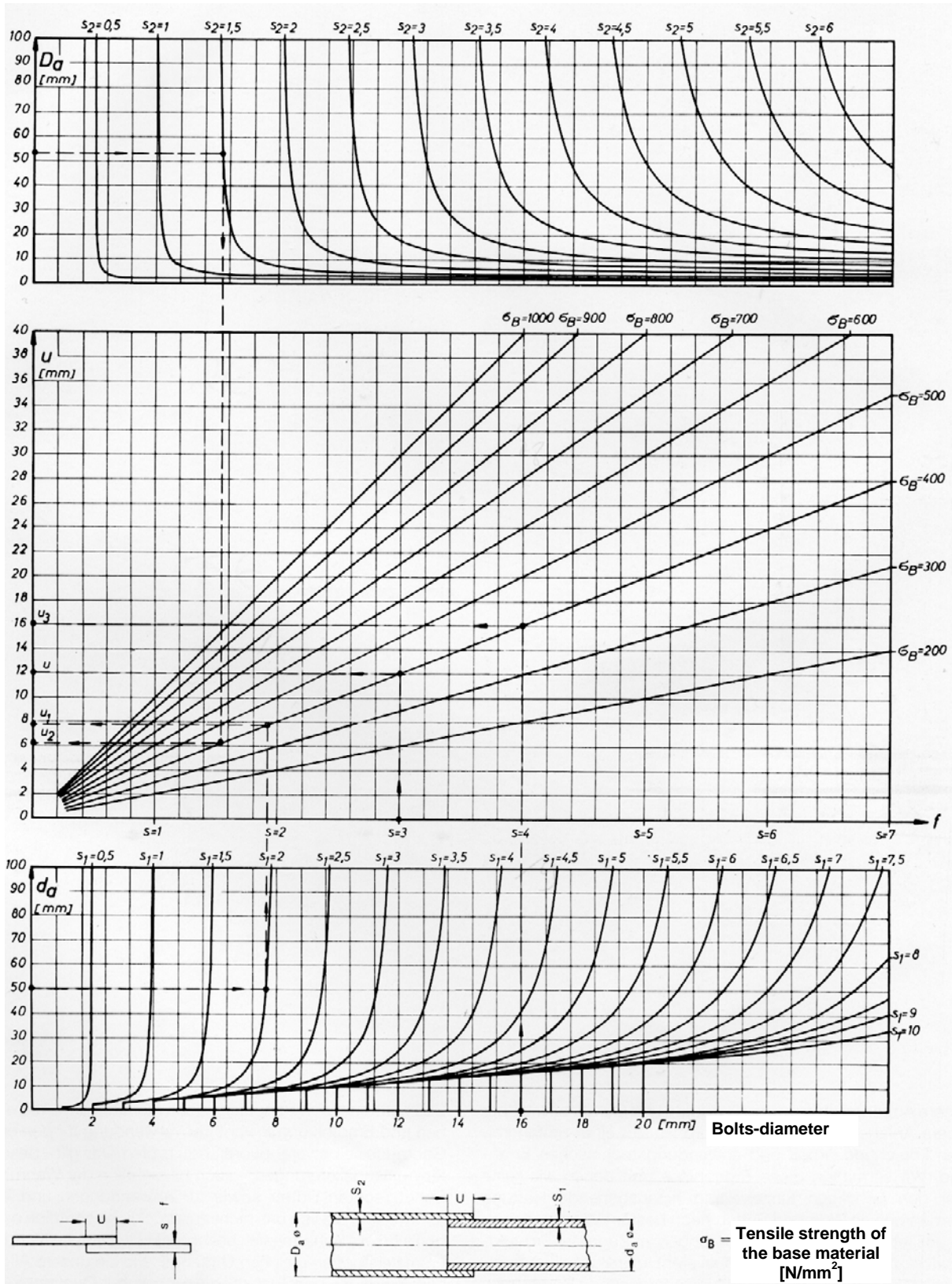

Table 5: Nomogram for determining the overlap length for overlapped brazed joints; e.g. sheets, pipes inserted into each other and inserted bolts.

Design of brazed joints

The information given about our products, equipment, plants and processes is based on extensive research work and our technical knowledge of applications. We provide this information verbally and in writing according to the best of our knowledge, but we do not accept any responsibility beyond that in the individual contract. We do however reserve the right to make technical changes as part of our product development activities. Our technical service personnel are available on request to provide further advice and assistance to solve manufacturing and technical problems.

This does however not relinquish users of their responsibility to check our information and recommendations prior to carrying out their own work. This is also true – especially for deliveries abroad – with regard to the observance of protection rights of third parties and with regard to applications and procedures not expressly given in writing by us. In the event of damage, our liability is limited to compensation to the same degree as provided for in our General Terms and Conditions of Sale and Delivery for shortcomings in quality.